

Clamshell Transfer Conveyor

MODEL # 10010

A fully adjustable, easy way to elevate clamshells from a filler to a packing table

How It Works

The Clamshell Transfer Conveyor efficiently elevates clamshells from a filler onto a packing table. This conveyor is easily adjusted (all by hand) to any height or angle you need in order to transfer packaged product from a filler at a lower height, or sitting at a right angle to a packing table.

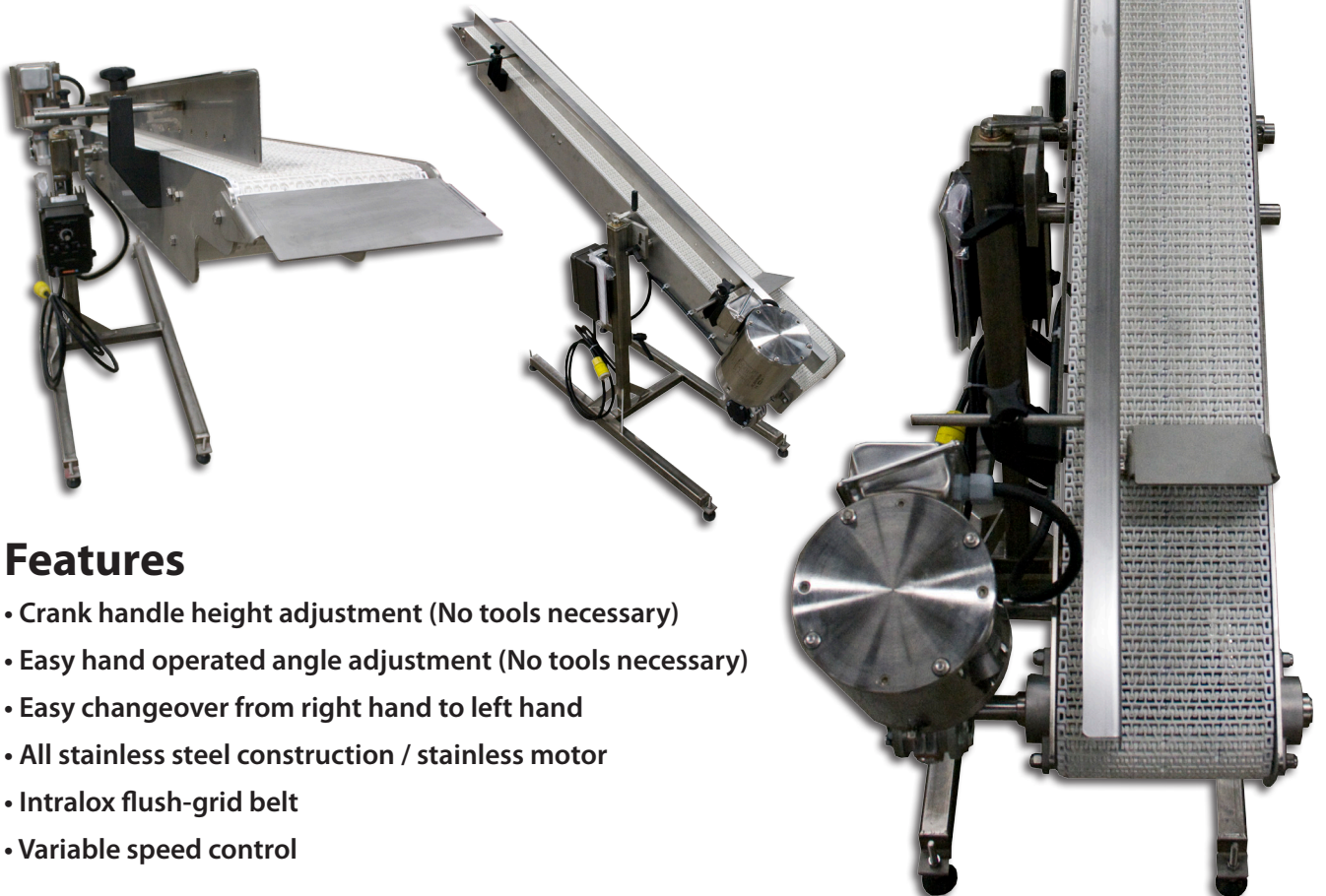

Features

- Crank handle height adjustment (No tools necessary)
- Easy hand operated angle adjustment (No tools necessary)
- Easy changeover from right hand to left hand
- All stainless steel construction / stainless motor
- Intralox flush-grid belt
- Variable speed control